



贝特卫士®

更好的电路安全卫士!  
You build electronics, We safeguard them!

# 承 认 书

## APPROVAL SHEET

编号 No.	7200700500-A/1-B
日期 Date	2021.07.02

客 户 Customer	
-----------------	--

品 名 Product	<b>High-Voltage Fuse</b>
系 列 Series	<b>720 series</b>

料号 Part No.	规格描述 Specification	备注 Remark
贝特电子 Betterfuse	<b>Φ6.5*40mm Glass tube,High rated voltage,Microwave Dedicated,Fast-Acting current fuse 5KV</b>	
客 户 Customer		

环保特别提示 Special instructions for environmental protection
本产品:

供应商-贝特电子 Supplier-Betterfuse	零件承认章 Approval Signet	客 户 Customer	零件承认章 Approval Signet
制 作 Make			
审 核 Check			
确 认 Approval			

联络 Contact			
业务 Sales	电话 Telephone	手机 Cellphone	邮箱 E-mail
零件承认后敬请回签一份给我司留存, 或将承认后的封面传真(0769-8352 1857)至我司, 谢谢!			



Document Record						
No.	Date	Modified Content	Page	Edition	Prepared/modified by	Checked by
1	2014.05.29	Release Edition		A/0	Kings Luo	Wenhua Yan
2	2018.03.05	Update TUV certification		A/1	J.Q.	Fei Gao
3						
4						
5						
6						
7						
8						
9						
10						
11						
12						

## TABLE OF CONTENTS

1. SCOPE AND DESCRIPTION.....	2
2. GENERAL INFORMATION.....	2
3. AGENCY APPROVALS.....	2
4. PART NUMBERING SYSTEM.....	3
5. MECHANICAL SPECIFICATIONS.....	3
6. ELECTRICAL SPECIFICATIONS.....	4
7. SOLDERING PARAMETERS.....	6
8. ORDERING INFORMATION.....	6
9. PACKING INFORMATION.....	7
10. APPENDIX.....	8



## 1. SCOPE AND DESCRIPTION



Following electronic product specifications apply to fuses of the 720 series. The 720 series is a quick-acting type high voltage fuse for over-current protection.

The 720 fuses can be used with high voltage and is fast acting with a high breaking capacity. It is mainly used in microwave ovens or similar applications.

## 2. GENERAL INFORMATION

### General Description

The 720 series quick-acting high voltage fuse is used for over-current protection mainly in microwave ovens. This 6.5x40mm device is constructed of a glass tube with electro-plated brass end caps. The 720 series offers excellent quality and protection and is 100% tested for cold resistance and precise length.

### Detailed Features

- High voltage fuse, mainly used for microwave ovens
- 6.5mm x 40mm physical dimensions
- Glass tube, nickel plated brass end caps
- Protection against harmful over-currents in primary and secondary applications.
- Lead-free, Halogen-free, RoHS compliant
- Designed compliant to IEC-60127-2/IV

## 3. AGENCY APPROVALS

Agency	Agency File Number	Ampere/ Voltage Range
	J50136139	5kV: 600mA; 650mA; 700mA; 750mA; 800mA; 850mA; 900mA



## 4. PART NUMBERING SYSTEM

### 4.1 Part Number

Example: 7200700500

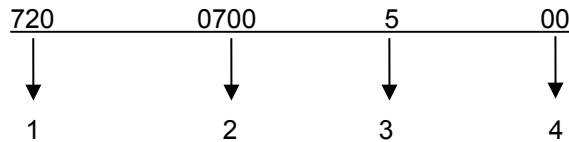

1 .....	Product Series .....	720
2 .....	Ampere Rating/ Code .....	700mA (see table 4.2 below)
3 .....	Voltage Rating .....	5 – 5000V
4 .....	Packaging Code .....	see table 4.2 below

### 4.2. Ampere Rating Table

AMP CODE	CURRENT RATING	VOLTAGE RATING
0400	400mA	5kV
0500	500mA	5KV
0550	550mA	5KV
0600	600mA	5KV
0650	650mA	5KV
0700	700mA	5KV
0750	750mA	5KV
0800	800mA	5KV
0850	850mA	5KV
0900	900mA	5KV
1100	1A	5KV

### 4.3. Supplementary Code

CODE	DESIGNATION
00	INormal product

## 5. MECHANICAL SPECIFICATIONS

Dimensions (units: mm)

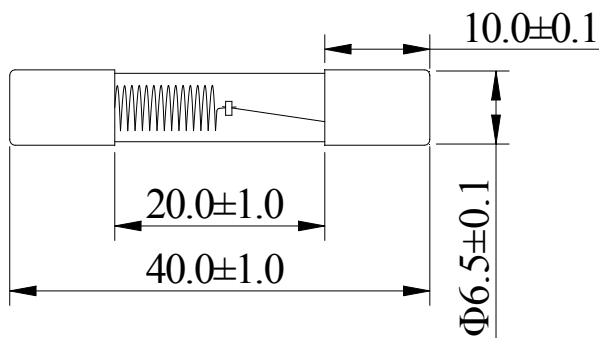

### Operating Temperature:

-55°C to 125°C

### Storage Conditions:

+10°C to +60°C  
Relative humidity: ≤ 75% yearly average  
without dew, maximum 30 days at 95%

### Vibration Resistance:

120 cycles in 1 direction at 1 min. each  
10-55Hz, 3 directions(X, Y, Z) in total  
According to MIL-STD-202 Method 201A



## 6. ELECTRICAL SPECIFICATIONS

### Time vs Current Characteristics Table

(measured with constant current power supply) (according to IEC 60127-2/ IV)

Time vs Current Characteristics: IEC 60127-2/IV						
Rated current	115%	150%	200%	275%	400%	1000%
400mA~1.25A	>4h	<300s	<20s	20ms~1500ms	8ms~400ms	≤80ms

Average Time Current (I-T Curves)

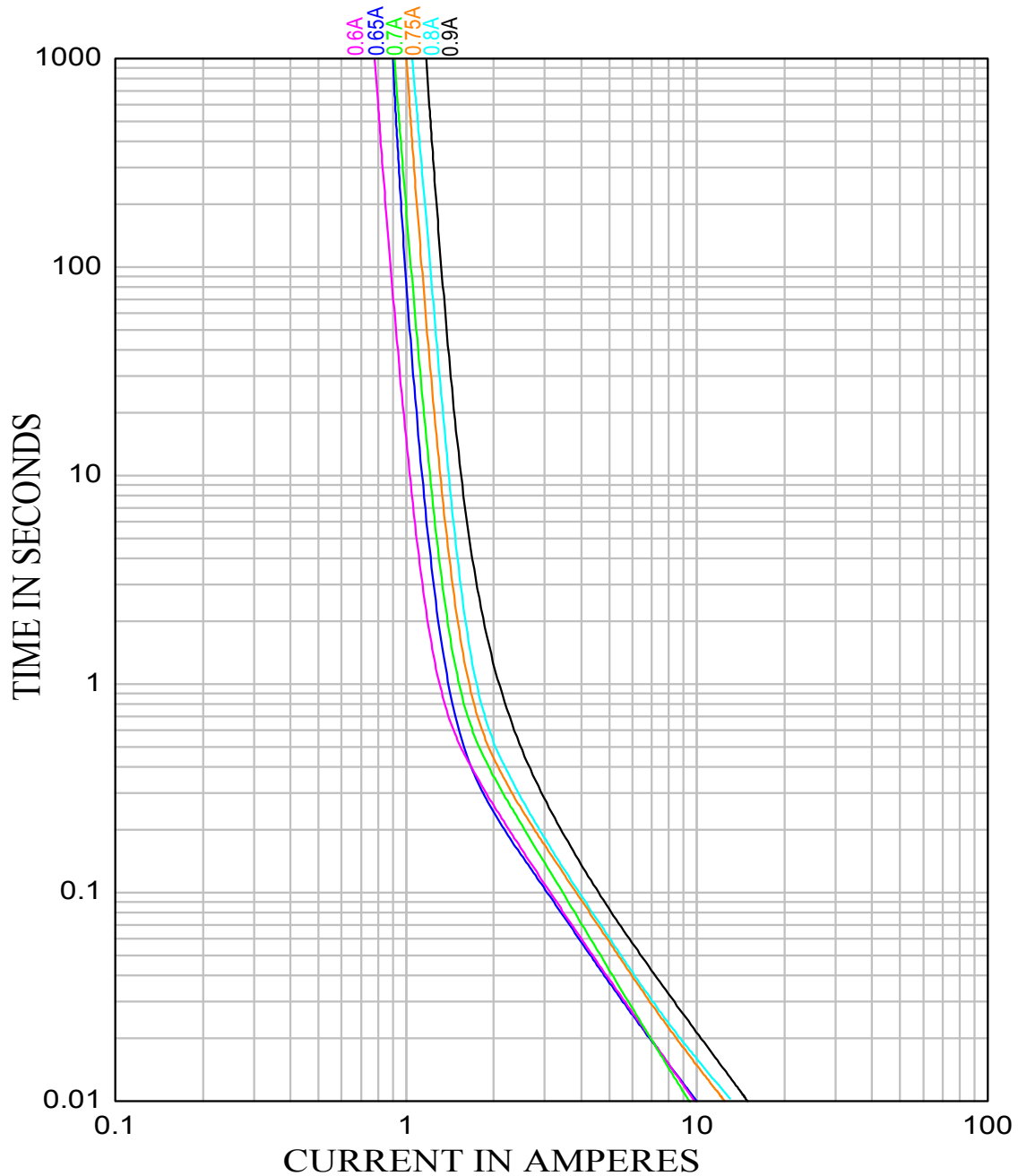



### Electrical characteristics

Electrical Characteristics					
Amp Code	Rated Current	Voltage Rating	Voltage Drop(mV) Max	Nominal Melting I <sup>2</sup> t(A <sup>2</sup> sec)	Approvals TUV
0400	400mA	5KV	1500	0.70	○
0500	500mA	5KV	1500	0.76	○
0550	550mA	5KV	1500	0.81	○
0600	600mA	5KV	1500	0.96	●
0650	650mA	5KV	1500	1.00	●
0700	700mA	5KV	1500	0.90	●
0750	750mA	5KV	1500	1.56	●
0800	800mA	5KV	1000	1.69	●
0850	850mA	5KV	1000	1.90	●
0900	900mA	5KV	1000	2.22	●
1100	1A	5KV	1000	2.34	○

### Temperature Derating Curve

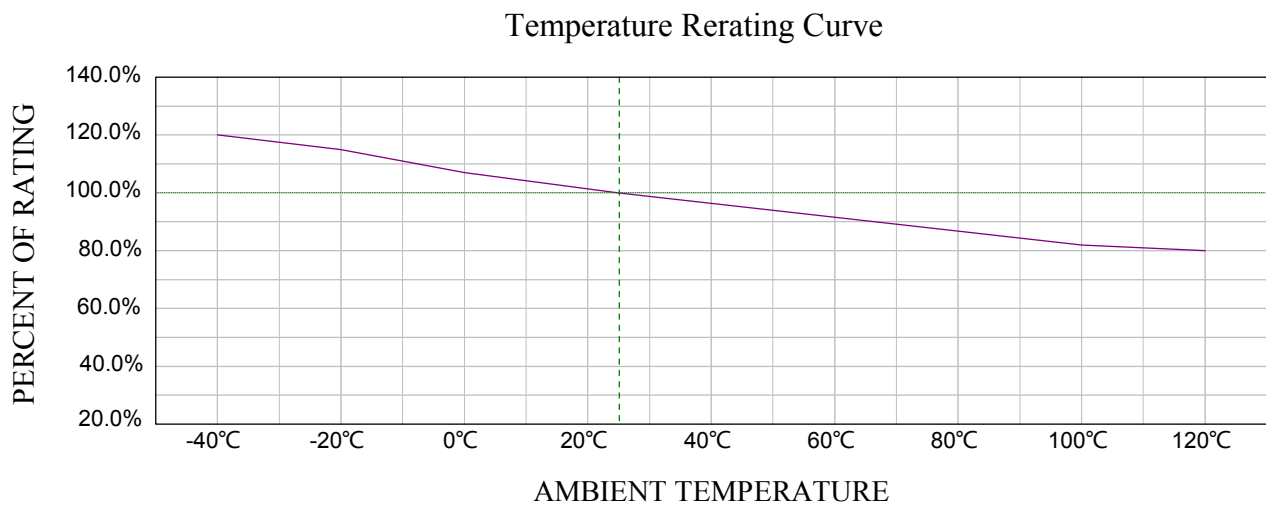

$$\text{Calculation for ideal fuse selection} = \frac{\text{Operating Current (A)}}{\text{Rating (\%} \times 0.75)}$$



## 7. SOLDERING PARAMETERS

260°C. ≤5 sec (Wave Soldering)

350°C. ≤3 sec (Hand Soldering)

Soldering Peak:

260°C - 10 sec (IEC 60068-20)

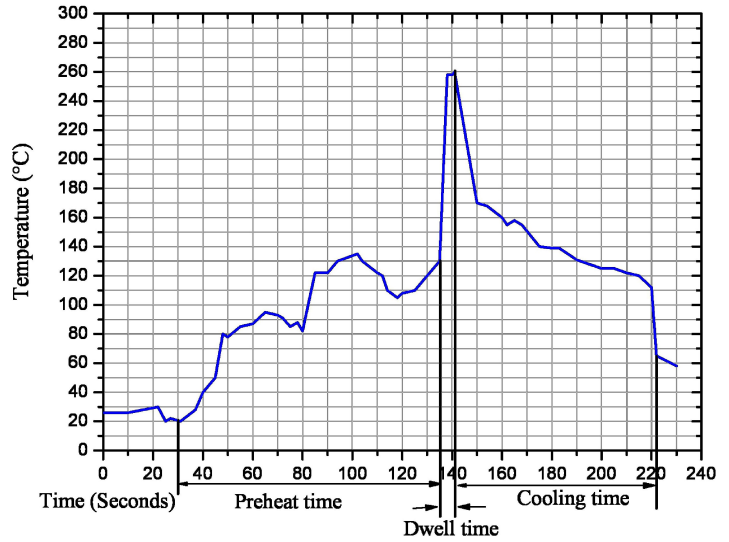

## 8. ORDERING INFORMATION

The following information are necessary in order to place your order with us correctly:

Series No.	Amp Code	Packaging Code	Quantity	Purchase Order No.
720				



## 9. PACKING INFORMATION

### Packaging details

Dimensions (unit: mm)

Inner Packaging plastic bag

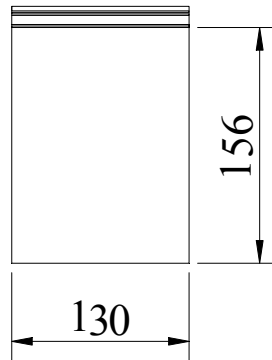

Inner Packaging Box

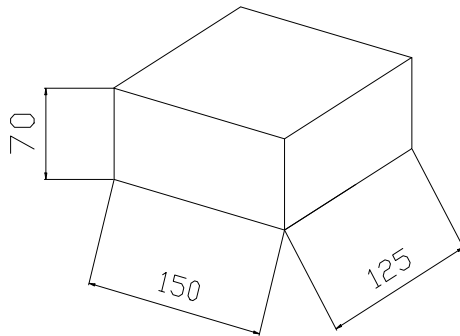

Master Carton

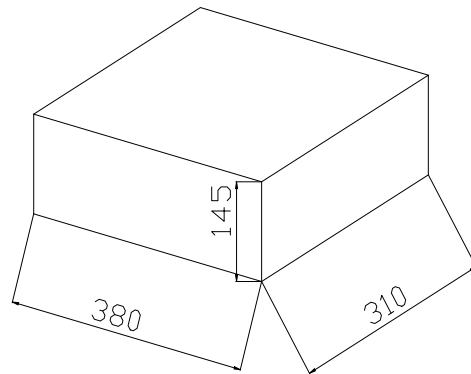

Net weight per bag	154g	Gross weight 400pcs per box	853g	Gross weight 4000pcs per carton	10.8Kg
Qty per bag	100pcs	Qty per box	400pcs	Qty per carton	4000pcs

© DongGuan Better Electronics Technology Co., Ltd

东莞市贝特电子科技股份有限公司

Room 601 of 16 Block, Xinzhu Yuan, No.4, Xinzhu Road, Songshanlake Hightech Industrial Development Zone, Dongguan City, Guangdong P.R.C  
中国广东省东莞市松山湖国家高新技术产业开发区新竹路4号新竹苑16座办公601

Tel: +86 769-2307 8212 Fax: +86 769-8352 1857

Web: [www.betterfuse.com](http://www.betterfuse.com)

Email: [info@betterfuse.com](mailto:info@betterfuse.com)