

477 Brick Fuse

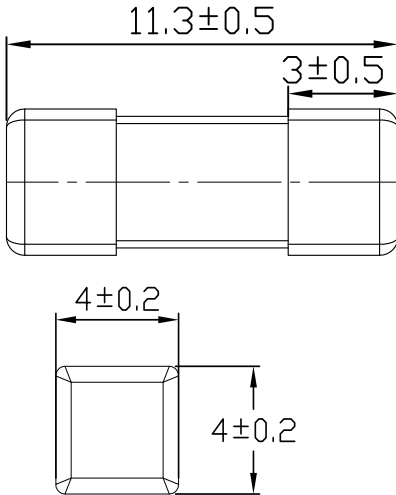

Dimensions(unit:mm)

Main Characteristics

Brick fuse; Time-Lag(T)

Standard

UL248-14

Materials

Body: Ceramic
 End Caps: Copper plated with silver

Operating Temperature

-55°C to +125°C

Stock Temperature

+10°C to +60°C

Relative humidity: ≤75% yearly average
 Without dew, maximum 30 days at 95%

Vibration Resistance

120 cycles in 1 direction at 1 min. each
 10-55Hz, 3 directions(X, Y, Z) in total
 According to MIL-STD-202 Method 201A

Soldering Parameters

260°C. ≤10 sec (Wave Soldering)

300°C. ≤2 sec (Hand Soldering)

Soldering Peak:

260°C. 10 sec.

280°C. 5 sec. (IEC 60068-20)

Average Time Current(I-T Curves)

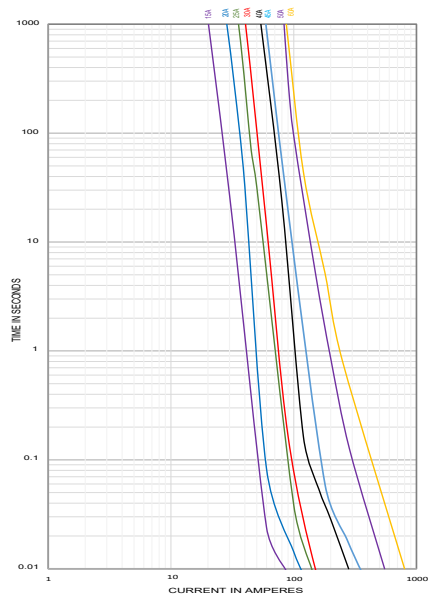

Time vs Current Characteristics: UL248-14

Rated Current	100%	200%
15~40A	>4H	<60s
45~60A	>4H	<240s



Electrical Characteristics at 25°C

Amp Code	Rated Current	Rated Voltage	Max. Voltage Drop (mV)	Breaking Capacity	Typical Melting I²t(A²sec)	Typical Cold Resistance (mΩ)	Approval	
							cURus	TUV
2150	15A	125V AC 250V AC 32V DC 72V DC	90	150A@125V AC 150A@250V AC 1000A@32V DC 500A@72V DC	72.3	3.65	•	•
2200	20A		90		132	2.78	•	•
2250	25A		75		196	2.16	•	○
2300	30A		70.2		225	1.78	•	○
2400	40A		68.5		756.25	1.16	•	○
2450	45A	125V AC 32V DC 60V DC 72V DC	60	250A@125V AC 1000A@32V DC 500A@60V DC *72VDC@200A	1198.8	0.93	•	○
2500	50A		50		3025	0.55	•	○
2600	60A		50		6400	0.50	•	○

- Note:** (1) Permissible continuous operating current is ≤100% at ambient temperature of 23°C (73.4°F)
 (2) The current values used for calculating I²T should be within the standard range of 8ms ~ 10ms.
 (3)*Breaking Capacity of 200A@72VDC is tested by internal.

Ordering Information

Series	Amp Code	Supplementary Code	Qty
477			